



# ROLLO

Laminoir  
Dough sheeter  
Uitroltafel



Modèle compact. Idéal pour les petites productions.  
Compact model. Ideal for small-scale productions.  
Compact model. Ideaal voor kleine producties.



# ROLLO



- Moteur et bac de fleurage intégré.
- Integrated motor and flour bin.
- Geïntegreerde motor en meelbakje.



- Les racleurs peuvent être enlevés sans outils.
- Scrapers can be removed without tools.
- De schrapers kunnen zonder werktuigen gedemonteerd worden.



- Manette pour la direction du laminage.
- Joystick for the rolling direction.
- Joystick voor de uitrolrichting.

- Avec grille de sécurité.
- With safety grid.
- Met veiligheidsrooster.

- Fourni avec 1 rouleau.
- Delivered with 1 rolling pin.
- Geleverd met 1 rolstok.



- Tapis en PVC.
- PVC conveyor belts.
- PVC transportbanden.

- Plaques de récupération.
- Collection trays.
- Opgvangplaten.

Max  
1,8 kg  
Pâte / Dough / Deeg



- Réglage précis de l'écart des rouleaux.
- Precise adjustment of the roller gap.
- Nauwkeurige afstelling van de uitrolhoogte.

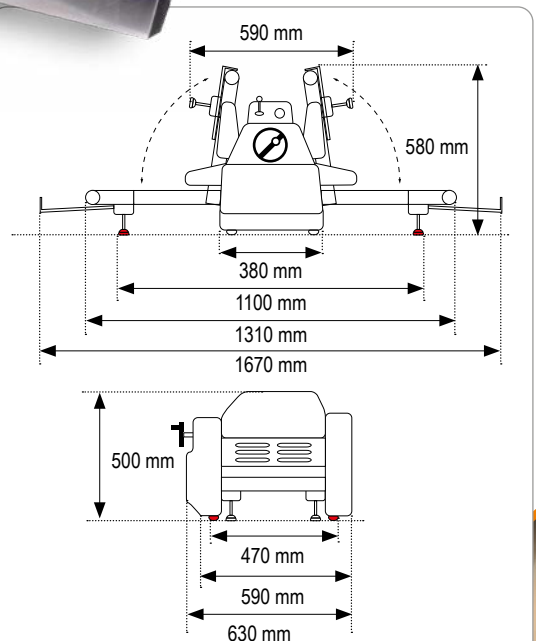

- Tables relevables et facilement démontables.
- Tables can be raised after operation and are easily removable.
- Opklapbare en eenvoudig uitneembare tafels.

## ROLLO

Largeur du laminage    Working width    Uitrolbreedte	37 cm
Longueur du tapis    Conveyor belt length    Lengte transportband	2 x 60 cm
Écart entre les rouleaux    Space between rollers    Ruimte tussen de rollen	0 - 25 mm
Poids net machine    Net weight machine    Nettogewicht machine	79 kg
Puissance moteur    Motor power    Motorvermogen	0,37 kW
Voltage    Voltage    Spanning	230 V 1Ph